

500A



HEWLETT-PACKARD COMPANY / OPERATING AND SERVICE MANUAL

500A
ELECTRONIC
FREQUENCY METER

500A

CERTIFICATION

THE HEWLETT-PACKARD COMPANY CERTIFIES THAT THIS INSTRUMENT WAS THOROUGHLY TESTED AND INSPECTED AND FOUND TO MEET ITS PUBLISHED SPECIFICATIONS WHEN IT WAS SHIPPED FROM THE FACTORY.

 FURTHER CERTIFIES THAT ITS CALIBRATION MEASUREMENTS ARE TRACEABLE TO THE NATIONAL BUREAU OF STANDARDS TO THE EXTENT ALLOWED BY THE BUREAU'S CALIBRATION FACILITY.

hp MANUAL CHANGES

MODEL 500A

ELECTRONIC FREQUENCY METER

Manual Serial 2589 & above

To adapt this manual to instruments with other serial prefixes check for errata below, and make changes shown in tables.

Instrument Serial Number	Make Manual Changes	#Manual Type Number	Make Manual Changes
2588 to 2315	1 and 2	Type 91048	1, 3, 4, 5, 6 and 8
2314 to 1199	1, 2, 3, 4 and 5	Type 6948	1, 3, 6, 7, 8 and 9
1198 to Type 2349	1, 3, 4, 5, 6 and 7	Type 12947	3, 4, 5, 6, 8 and 10
Type 2349	1, 3, 4, 5, 6 and 7	Type 6447	3, 4, 5, 6, 8 and 10

- CHANGE 1 R50: Change to 82,000 ohms; Ⓟ Stock No. 24-82K.
- CHANGE 2 R31: Change to 22,000 ohms; Ⓟ Stock No. 24-22K.
- CHANGE 3 R30: Change to 270K ohms; Ⓟ Stock No. 24-270K, added in series with lead to V5, pin 5.
C7: Change to 3 section/ 10 μ f per section; Ⓟ Stock No. 18-31. Two sections are connected to V6, pin 8.
- CHANGE 4 C32: Delete
- CHANGE 5 C8: Connect across the output of bridge rectifier CR1 to CR4.
- CHANGE 6 R31: Change to 120K ohms; Ⓟ Stock No. 24-120K.
R53: Change to 1380 ohms; Ⓟ Stock No. 31-1380.
R58, 59: Delete
C31: Delete
- CHANGE 7 R57: Change to 100 ohms; Ⓟ Stock No. 24-100, connected in series with R53.
- CHANGE 8 R48: Change to 47,000 ohms.
- CHANGE 9 C32: Should be designated C8.

#For instruments below about Serial 200, manuals were identified by a date code (Type) rather than by serial number. The date code indicated the month, day and year, in that order.

3/28/62 - R

3/9/62 - BD

Manual Changes Model 500A Page 2

Instrument Serial Prefix

Make Manual Changes

Instrument Serial Prefix

Make Manual Changes

CHANGE 10

C3: Change to 0.1 μ f.

C29,30: Delete

R1: Change to 390K ohms.

R2, 3: Change to 680K ohms.

R4: Change to 4.7M.

R8: Change to 2.2M.

R26: Change to 270K ohms.

R45: Change to 5,000 ohms.

R46: Change to 100K ohms.

R50: Change to 100K ohms; $\text{\textcircled{P}}$ Stock No. 24-100K.

INSTRUCTION AND OPERATING MANUAL
FOR

MODEL 500A

ELECTRONIC
FREQUENCY METER

Serial 2589 and Above

Copyright 1954 by Hewlett-Packard Company
The information contained in this booklet
is intended for the operation and main-
tenance of Hewlett-Packard equipment and
is not to be used otherwise or reproduced
without the written consent of the Hewlett-
Packard Company.

HEWLETT-PACKARD COMPANY
395 PAGE MILL ROAD, PALO ALTO, CALIFORNIA, U. S. A.

General Description

The Model 500A Frequency Meter directly measures the frequency of an alternating current voltage from 5 to 50,000 cycles/sec. It will operate with the input voltage as low as .5 volts. Variation of the input voltage from .5 to 200 volts or variation of line voltage from 105 to 125 volts has very little effect on the accuracy of the instrument.

This instrument is useful for measuring the beat frequency between two radio frequency signals, crystal frequency deviation, audio frequencies, and for measuring the speed of rotating machinery when used in conjunction with a photo tube and a light source.

CAUTION

THE MAXIMUM VOLTAGE APPLIED TO THE INPUT TERMINALS OF THIS INSTRUMENT MUST NOT EXCEED 600 VOLTS, THE SUM OF THE DC VOLTAGE AND THE AC PEAK VOLTAGE. HIGHER VOLTAGES WILL BREAK DOWN THE CAPACITOR IN THE INPUT CIRCUIT OF THIS INSTRUMENT.

Parts Substitutions

Difficulties in procuring some of the parts used in this instrument may cause the electrical or physical values to deviate from those shown in this instruction manual. These substitutions have been made so as not to impair the performance of this instrument. Whenever replacement of any of these parts is necessary, either the substitute value or the original value may be used.

TABLE OF CONTENTS

MODEL 500A

ELECTRONIC FREQUENCY METER

	<u>Page No.</u>
Specifications	1
Operating Instructions	
Inspection	2
Controls and Terminals	2
Operation	4
Circuit Description	6
Maintenance	
Cover and Bottom Plate Removal	7
Tube Replacement	7
Meter Zero Adjustment	7
Hum Balance Adjustment (R55)	7
Frequency Calibration Adjustment	7
Adjustment of Current Regulator	8
Trouble Shooting	9
Table of Replaceable Parts	10

INSTRUCTIONS

MODEL 500A

ELECTRONIC FREQUENCY METER

Specifications

Frequency Rating --

Range - 10 to 50,000 cycles/sec. in ten ranges.

Full Scale Indication - 50, 100, 200, and 500 cycles/sec.
1, 2, 5, 10, 20, and 50 KC/sec.

Input Voltage --

Minimum Input Voltage - .5 volts Variation of the input voltage from
.5 to 200 volts will affect the meter indication not more than $\pm 1\%$.

Input Impedance --

Approximately 300,000 ohms shunted by 37 μmf .

Accuracy --

$\pm 2\%$ of full scale.

Voltage Stability --

Power line voltage variations from 105 to 125 volts will affect the meter
indication less than $\pm 1\%$.

Recorder Output Characteristics --

Current - 1 ma.

Resistance - 1400 ohms ± 100 ohms

Power Supply Rating --

Voltage - 105 to 125 volts/210 to 250 volts

Frequency - 50 to 1000 cycles/sec.

Wattage - 65 watts

Overall Dimensions --

Cabinet Model - 19" wide x 8-1/2" high x 11-1/2" deep

Rack Model - 19" wide x 8-3/4" high x 11-1/2" deep

Panel Size - 19" x 8-3/4"

Depth Behind Panel - 10-1/2"

Weight --

Cabinet Model - 20 lbs.
Rack Model - 20 lbs.

Operating Instructions

Inspection --

This instrument has been thoroughly tested and inspected before being shipped and is ready for use when received.

After the instrument is unpacked, the instrument should be carefully inspected for damage received in transit. If any shipping damage is found, follow the procedure outlined in the "Claim for Damage in Shipment" page at the back of this instruction book.

Controls and Terminals --

INPUT - These binding posts are connected to the input circuit of the frequency meter. The binding post marked G is connected to the chassis.

CAUTION

THE MAXIMUM VOLTAGE APPLIED TO THE INPUT TERMINALS OF THIS INSTRUMENT MUST NOT EXCEED 600 VOLTS, THE SUM OF THE DC VOLTAGE AND THE AC PEAK VOLTAGE. HIGHER VOLTAGES WILL BREAK DOWN THE CAPACITOR IN THE INPUT CIRCUIT OF THIS INSTRUMENT.

TEST - This switch is provided for testing the input voltage level to determine if it is adequate to operate the instrument.

PHOTOTUBE - This jack is provided for connecting a phototube to the instrument to convert the instrument to an electronic tachometer. When the plug is inserted in this jack, the input circuit is changed to match the characteristics of a type 1P41 phototube.

USE-LINE FREQ - CALIBRATE - This switch is used to connect the indicating meter and input circuit to perform several functions. The switch position and corresponding functions are listed below.

Switch Position

Function

USE

The meter is connected to indicate frequency and the INPUT terminals are connected to the input of the amplifier.

LINE FREQ.

The meter is connected to indicate frequency. The 6.3 V.

500A 4/24/53 Serial 1765 and above

secondary of the power transformer is connected across the input of the amplifier in order to measure the power line frequency as a check on the instrument calibration.

CALIBRATE

The meter is connected as a DC milliammeter to measure the current drawn by the switching tubes (V4, V5). The current is adjusted so that the meter pointer coincides with the calibration mark on the meter scale. The amplifier input is short circuited when the switch is in this position.

RANGE - This switch is used to insert the correct coupling capacitors and meter shunt resistors in the circuit for any desired range of frequency measurement.

CALIBRATE - This control is used to adjust the current drawn by the switching tubes.

RECORDER - The RECORDER jack is provided for connecting a recorder to the instrument. This instrument is designed to drive an Easterline-Angus Automatic Recorder. However, other recorders may be substituted if their resistance is 1400 ohms \pm 100 ohms and a full scale indication can be obtained with a current of one milliamper.

ON - OFF - This toggle switch controls all the power supplied to the instrument from the power line.

FUSE - The fuseholder, located on the back of the instrument, contains a 1 ampere cartridge fuse. To replace the fuse, unscrew the fuseholder cap and remove the blown fuse, insert a new fuse of the same type and replace the fuseholder cap. For 230 volt operation this fuse should have a 1/2 ampere rating. Replacement fuses must be of the "Slo-Blo" type as specified in the Table of Replaceable Parts in this instruction manual.

Power Cable - This is a special three conductor power cable with a standard two prong male plug molded on one end. The third conductor (green) protrudes from the power cable near the plug and may be used to connect the instrument chassis to an external ground.

Operation --

The procedure for measuring frequency is as follows:

1. Turn the power switch to ON and allow the instrument to warm up for two or three minutes. If maximum accuracy is desired, measurements should not be made until the instrument is completely warmed up.

2. Set the USE-LINE FREQ. -CALIBRATE switch to the CALIBRATE position. Adjust the CALIBRATE control so that the meter pointer coincides with the meter scale division labeled "C" - located at approximately 85 on the 0-100 meter scale. This step in the procedure calibrates the instrument. The calibration should be rechecked occasionally while making measurements.

3. Set the RANGE switch to the 100 Ω range. Change the USE-LINE FREQ. -CALIBRATE switch to the LINE FREQ. position. The frequency of the power line voltage is indicated by the meter. This measurement serves as a check on the calibration of the instrument.

CAUTION

No external voltage should be applied to the input terminals when the power line frequency is being measured. Application of external voltage may cause inaccurate line frequency measurements.

4. Change the USE-LINE FREQ. -CALIBRATE switch to the USE position and apply the voltage to be measured to the INPUT terminals. Set the RANGE switch to cover the frequency being measured. If the approximate frequency is unknown, turn the RANGE switch to the highest frequency range. Change the switch to successively lower ranges until a range is found that produces a readable meter indication.

5. While the meter is indicating the frequency being measured, depress and hold in the TEST button. If the meter indication is unchanged by this test, then there is sufficient input voltage for the instrument to produce an accurate frequency measurement. Insufficient input voltage, as shown by a lowered meter indication when the TEST button is pressed, will cause inaccurate frequency measurements.

Attaching a Recorder to the Model 500A -

When a recorder is used with the Model 500A, it is necessary that the compensating resistor in the instrument be adjusted so that the resistance of the recorder matches the instrument.

This adjustment is made as follows:

1. Warm up the instrument and measure either the power line frequency or the frequency of an audio oscillator. Note the frequency indicated by the meter.

2. Plug the lead from the recorder into the RECORDER jack. If the meter (M1) indication is not the same as noted in step 1, adjust R56 (See Fig. 4) so as to produce the same indication as in step 1. When the recorder is disconnected from the RECORDER jack, resistor R56 is removed from the circuit and R53 substituted so that the accuracy of the Model 500A is not impaired.

Using the Model 500A as a Tachometer -

The Model 500A may be employed as a tachometer by connecting a suitable phototube to the instrument. A source of light to be reflected into the phototube, by a target painted on the rotating machinery being measured, must also be provided.

The above mentioned phototube and light source have been combined into one assembly and may be purchased from the Hewlett-Packard Co. This accessory is called a Model 506A Tachometer Head Assembly.

Zero Meter Indication - The meter pointer may not coincide with the zero scale mark when the instrument is not operating. The meter pointer is correctly adjusted and the adjustment screw sealed at the factory.

500A 4/24/53 Serial 1765 to

Circuit Description

The Model 505A (or 505B) Electronic Tachometer Indicator consists of a limiting amplifier, an electronic switch, a pulse counter circuit, a constant current regulator, and a power supply.

The incoming voltage of unknown frequency is applied to the grid of V1, the first stage of the limiting amplifier (tubes V1, V2, V3). Tubes V1 and V2 amplify and flatten the peaks of the incoming voltage. Tube V3 is a phase inverter.

The square waves obtained from the plate circuits of tubes V2 and V3, opposite in phase, are applied to the grids of tubes V4 and V5, which comprise the electronic switch.

The space current for the two switching tubes is obtained from the constant current regulator. The proper pair of pulse-counter capacitors for the desired range is selected by the RANGE switch, which at the same time selects the proper shunt resistor for the meter. When the square wave from V2 is in the positive half of the cycle, switching tube V4 is biased to conduct, and current from the regulator flows through V4 to charge one of the capacitors in the C9-C18 group. When the voltage on the grid of V4 becomes negative, the wave from phase inverter V3, applied to the grid of V5, is in the positive half of the cycle. Switching tube V5 in turn conducts, and current from the regulator flows through V5 to charge one of the capacitors in the C19-C28 group. The time constants of the two RC combinations (load resistor R33/capacitor from C9-C18 group and load resistor R32/capacitor from C19-C28 group) are equal. The resistor and capacitor values are such that, at the highest frequency to be counted, the capacitor will be fully charged before the end of the half cycle. The accurately controlled pulses from the pair of capacitors are converted to unidirectional pulses by crystal-rectifiers CR1-CR4, and the resultant current flows through the meter. The meter indication is proportional to the number of pulses per unit of time and therefore to the frequency of the voltage applied to the input of the instrument. Resistors R34 to R43 are shunts, one of which (selected by the RANGE switch) is connected across the meter to adjust the current through the meter to the correct value for the selected frequency range.

Two resistors (R53 and R56) are connected to contacts of the RECORDER jack, but only one resistor is in the circuit at any one time. With the jack at normal, variable resistor R56 is shunted, and resistor R53 is connected into the meter circuit. Resistor R53 constitutes a dummy load approximately equivalent to the load a recorder presents, and is inserted in the circuit when no recorder is connected to the instrument. With a plug in the RECORDER jack, resistor R53 is disconnected from the circuit, and resistor R56 is inserted. Adjustment of the Model 505A (or 505B) recorder circuit to that of the recorder within a 1400 ± 100 ohms limit is made by means of variable resistor R56.

The constant current regulator consists of tubes V7, V8. Tube V8 is a voltage regulator tube which maintains a constant voltage on the screen grid of tube V7. A voltage divider (R48, R49, R50) is connected between the screen grid and ground. The variable resistor (R49) in this divider is provided so that the voltage applied to the grid of V7 may be adjusted to produce the desired constant current for the switching tubes. This current is measured by switching the meter (M1) across resistor R27 in the plate circuit of tube V7.

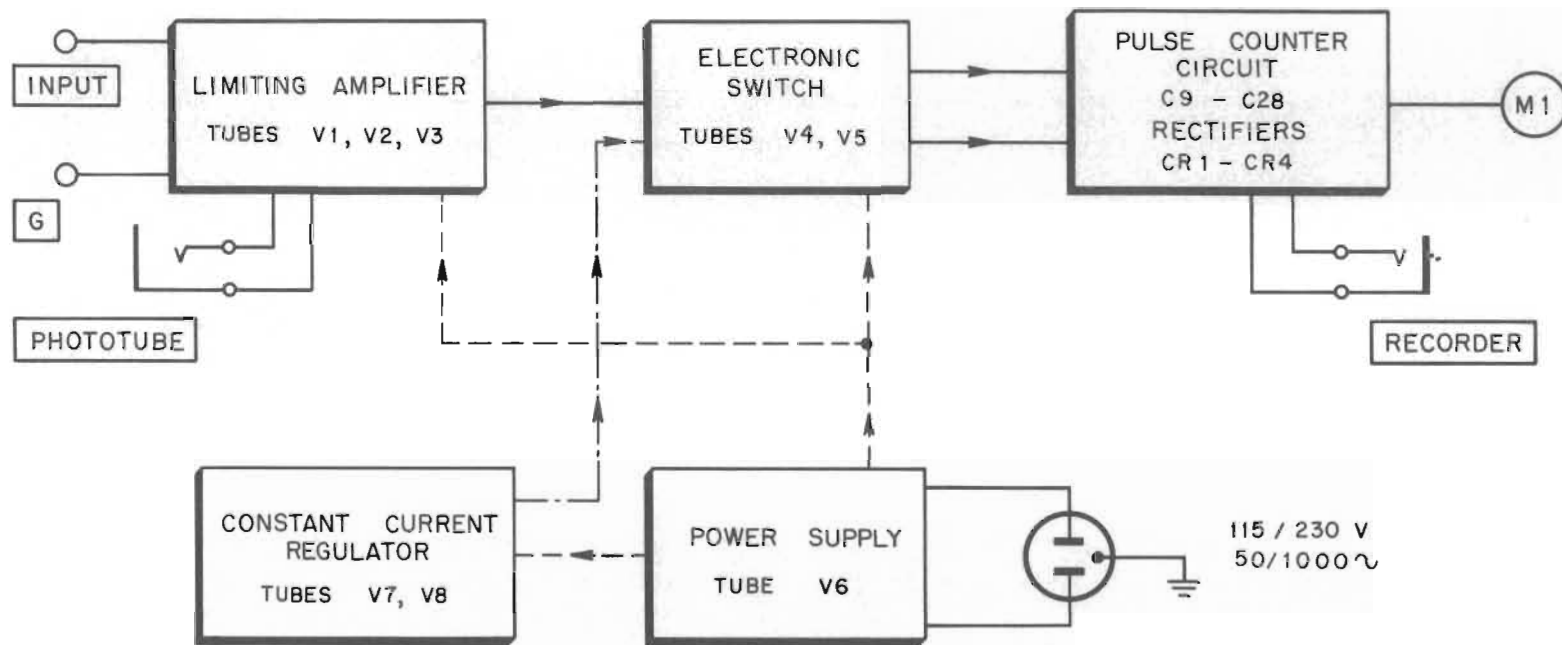

Fig. 1. Model 500A Block Diagram

Maintenance

Cover and Bottom Plate Removal --

The bottom plate is removed by unscrewing the four screws, one in each corner of the bottom plate, which fasten the plate to the chassis.

The cover is removed by unscrewing the eight screws which fasten the cover to the back and top of the instrument.

Tube Replacement --

Any tube having RETMA standard characteristics may be used for replacement purposes in this instrument.

Meter Zero Adjustment --

The meter zero adjust screw is sealed at the factory for the best tracking of the meter, and no attempt should be made to change this adjustment. If the meter pointer does not indicate exactly on zero, the accuracy of the meter need not be doubted.

CAUTION: The method used by the factory to seal the zero adjust screw is such that any attempt to move the screw will damage or break it.

Hum Balance Adjustment (R55) --

The adjustment for balancing out the unwanted power line current is as follows:

1. Measure the power line frequency (Operation, step 3), and note the meter indication. Shield the INPUT terminals of the instrument. A shielded double banana plug is satisfactory.
2. Set the USE-LINE FREQ. -CALIBRATE switch to USE and the RANGE switch to the 50 μ position.
3. Adjust variable resistor R55, located underneath the chassis and reached by removing the bottom plate (see Fig. 4, for minimum meter (M1) indication.
4. Again measure the line frequency and compare with the previous line frequency measurement. If they are not the same, readjust R55 slightly to one side to obtain the same meter indication as in step 1.

Frequency Calibration Adjustment --

The only calibration adjustment that should be performed in the field is the adjustment of the meter shunt resistors, R34 to R43. If any of the coupling capacitors, C9 to C28, are affecting the calibration, the instrument should be returned to the factory for adjustment.

The procedure for adjusting the shunt resistors is as follows:

1. Warm up the instrument and set the controls for frequency measurement.

2. Starting with the RANGE switch at the 50 μ position, apply a 50 μ voltage to the INPUT terminals of the instrument. This voltage should be obtained from a secondary frequency standard or some other source of accurate frequencies. If the meter does not indicate exactly full scale, then adjust the value of shunt resistor R34 by substituting another resistor or by connecting a high resistance in parallel with R34.

3. Repeat step 2 for 100 μ , 200 μ and etc. using a calibration voltage whose frequency is equal to the full scale frequency of each range. Adjust the shunt resistor which corresponds to the range being calibrated.

Adjustment of Current Regulator --

The procedure for adjusting the constant current regulator circuit is as follows:

1. Warm up the instrument using 115V (or 230V) line voltage. Set the USE-LINE FREQ. -CALIBRATE switch to CALIBRATE. Adjust the CALIBRATE control so that the meter indicates exactly 80 on the 0 to 100 scale.

2. Change the line voltage to 105 (or 210V) volts and note the meter indication. Repeat at 125 (or 250V) volts line voltage. If the meter indication does not change more than $\pm 1\%$ of full scale (80.5 to 79.5), then the regulator circuit is functioning satisfactorily.

3. If the meter indication is not within the specified limits, then a new OD3 tube (V8) and/or a new 6L6 tube (V7) should be tried. The OD3 tube should be aged by operating it for eight hours with 150 volts applied across its terminals. The easiest way to age the tube is to put it in its socket in the instrument and let the instrument operate for eight hours.

If changing tubes does not restore the regulator circuit to normal, then additional adjustments will be necessary.

4. With the line voltage at 115 (or 230V) volts, set the USE-LINE FREQ. -CALIBRATE switch at CALIBRATE. Set the CALIBRATE control to produce a meter indication of 80, then change the USE---CALIBRATE switch to USE and apply a 50,000 cycles/sec. voltage to the INPUT terminals. Note the meter indication.

5. Adjust R61 (See Resistor Board Detail RB1, Fig. 5) by connecting a resistor in parallel with R61 or by substituting a new resistor of higher value, so that the meter does not vary more than $\pm 1\%$ of full scale when the power line voltage is varied from 105 to 125 (or 210 to 250V) volts.

6. Without changing the CALIBRATE control, change the RANGE switch and input frequency to 1000 cycles/sec. Note the meter indication with 115 (or 230V) volts power line voltage. Change power line voltage to 105 and 125 (or 210 and 250V) volts and note any variations from the indication obtained at 115 (or 230V) volts. If the variation is $\pm 1\%$ or less, the circuit is correctly adjusted.

However, if the variation is more than $\pm 1\%$ then the value of R61 should be changed so as to obtain the best compromise between the 1000 and 50,000 cycles/sec. adjustments.

Trouble Shooting --

The following information is designed to aid in trouble shooting a defective instrument:

<u>Symptoms</u>	<u>Possible Cause</u>	<u>Test Procedure</u>	<u>Remedies</u>
Instrument NOT operating, pilot light NOT on.	Line fuse blown due to defective fuse or overload in power supply section of instrument.	<p>Replace fuse, if this fuse blows remove V6 (5Y3GT) and again replace the fuse. If this fuse blows it indicates:</p> <ol style="list-style-type: none"> 1. Short circuit in wiring associated with power transformer. 2. Short circuit in filament wiring. 3. Tube with an internal short circuit. 4. Defective power transformer. <p>If the fuse does not blow with V6 removed, it indicates:</p> <ol style="list-style-type: none"> 1. Defective filter capacitor C31, C7AB. DC resistance between pin 8 on V6 socket and ground is normally 17,000 ohms (approximate) and should be measured with the instrument disconnected from the power line. 2. Short in direct current wiring. 	<ol style="list-style-type: none"> 1. Locate and clear short circuit. 2. Locate and clear short circuit. 3. Replace defective tube. 4. Replace power transformer.
Instrument NOT operating, pilot light ON.		<ol style="list-style-type: none"> 1. Defective tube. 2. Measure DC voltages. Should agree with those indicated on schematic diagram within $\pm 10\%$. 	<ol style="list-style-type: none"> 1. Replace defective tube. 2. Replace component causing incorrect DC voltage.
Low meter indication on all ranges.	Defective crystal rectifier.	Measure the back resistance of each crystal rectifier. CR1 - CR4. Back resistance must be 30,000 ohms or greater.	Replace defective crystal rectifier.

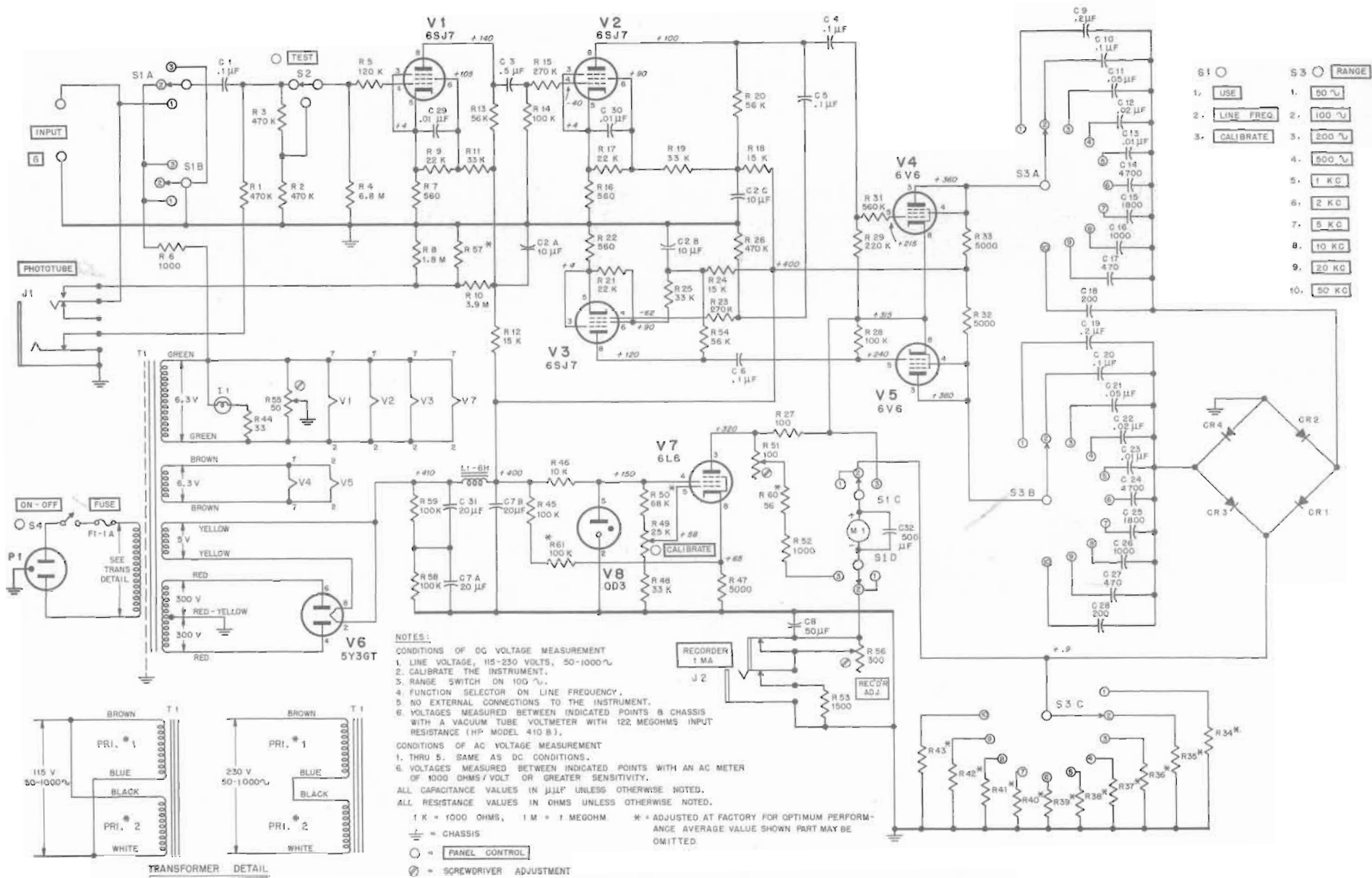

SCHMATIC DIAGRAM OF MODEL 500A

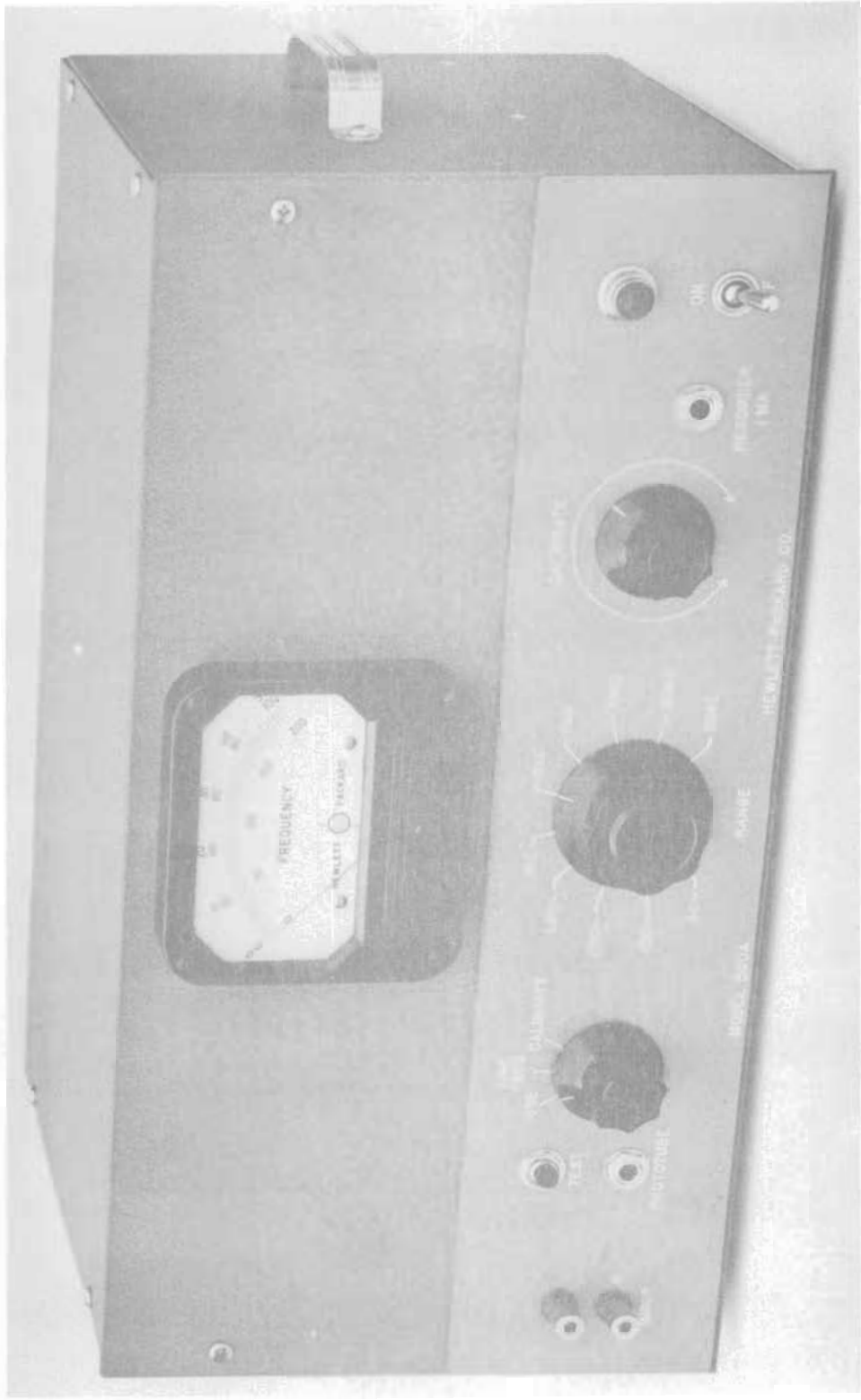

Fig. 2. Model 500A Electronic Frequency Meter

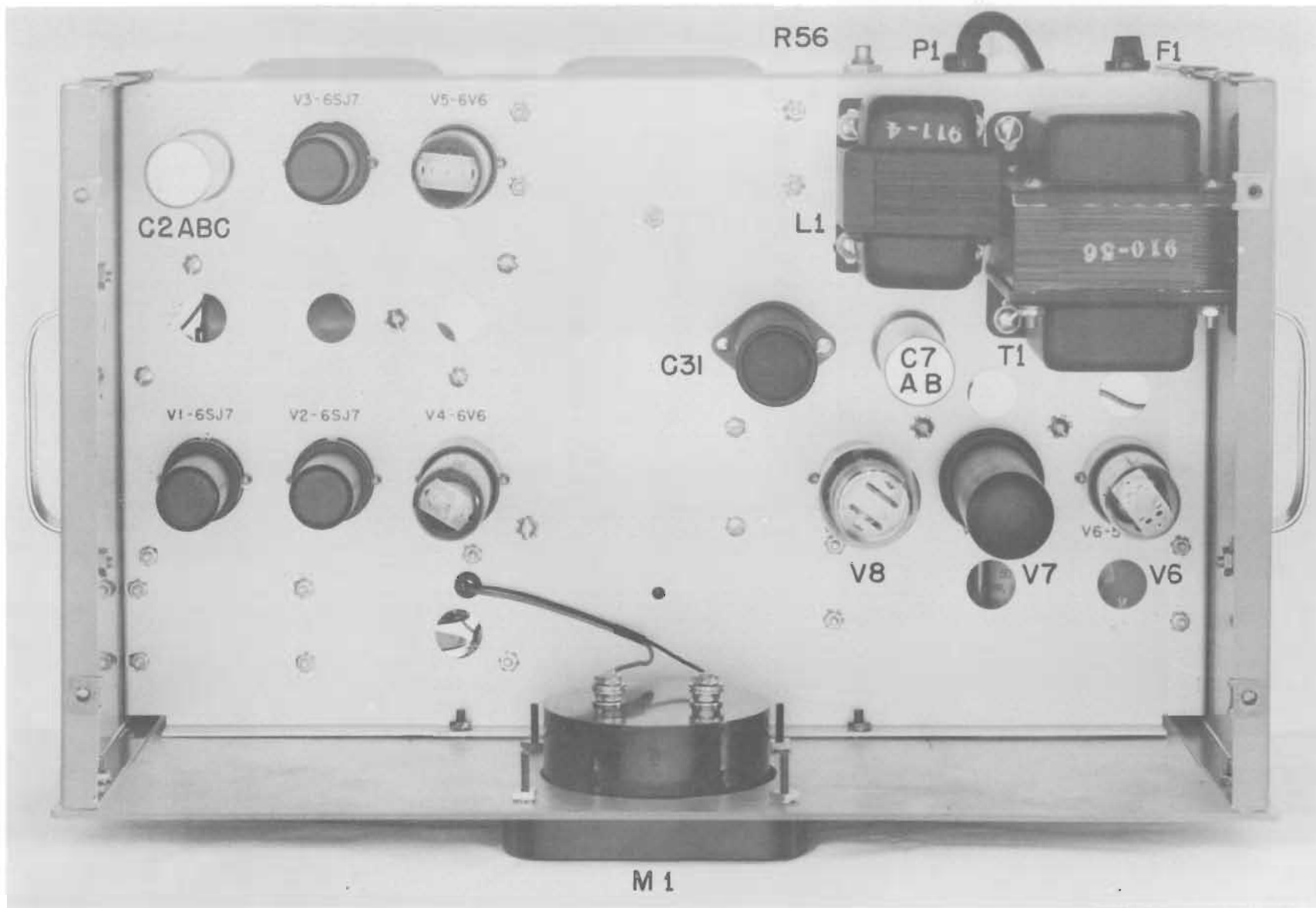

Fig. 3. Model 500A Top View Cover Removed

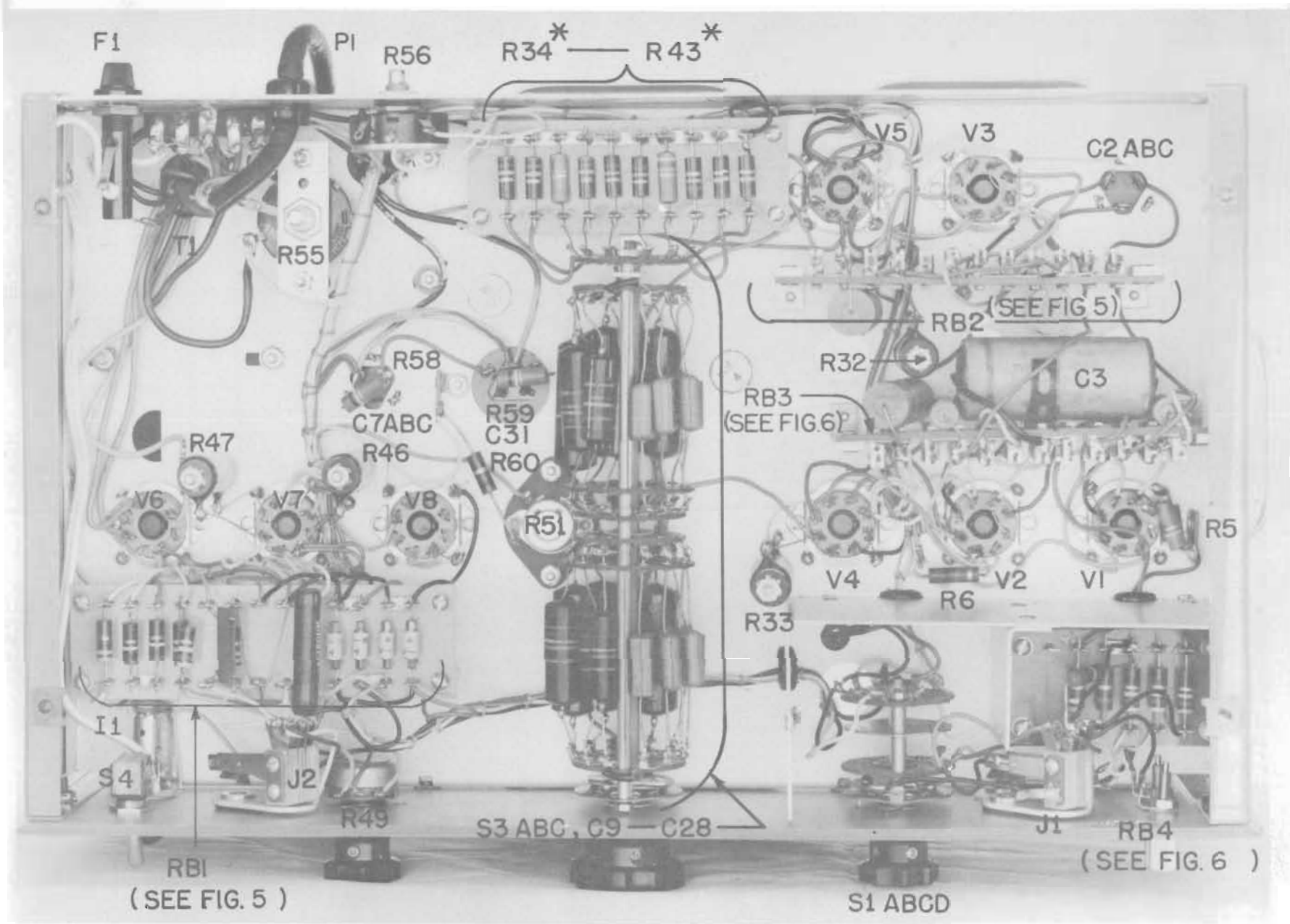
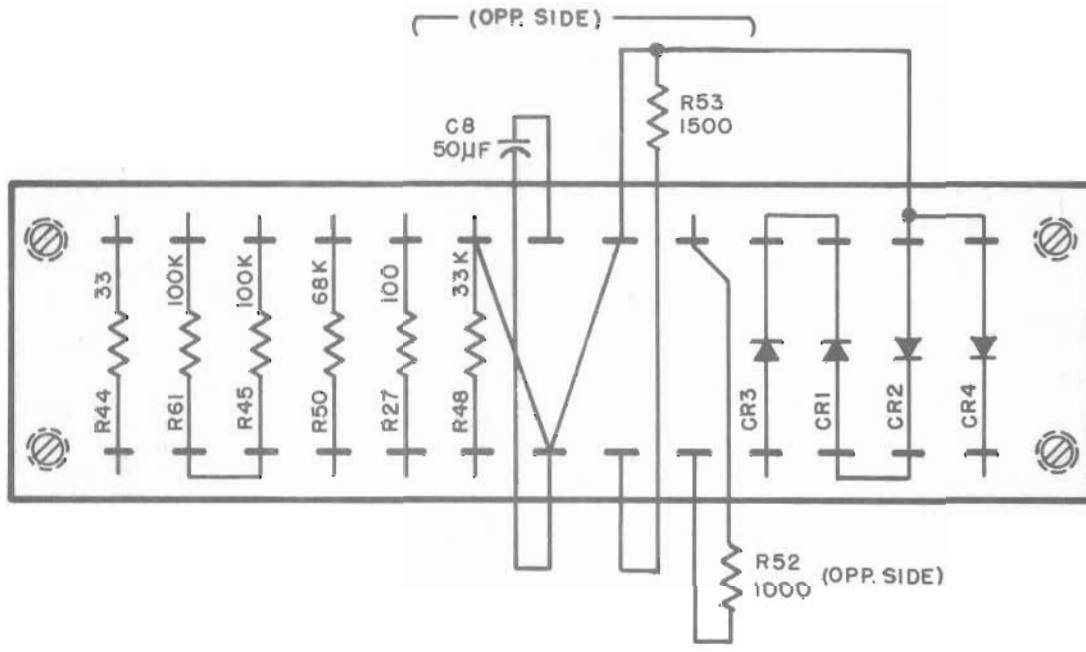
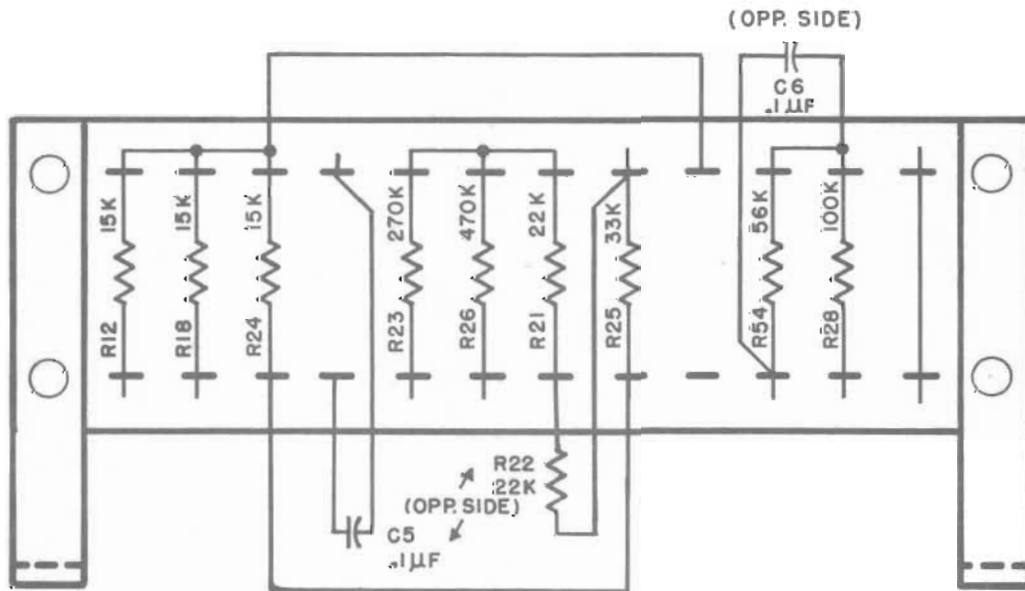

Fig. 4. Model 500A Bottom View Bottom Plate Removed



RB1



RB2

Fig. 5. Model 500A Resistor Board Detail

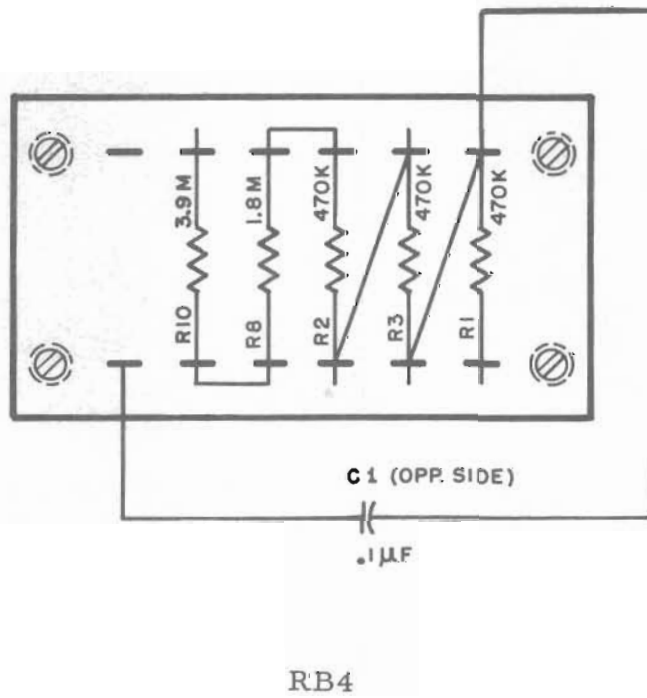
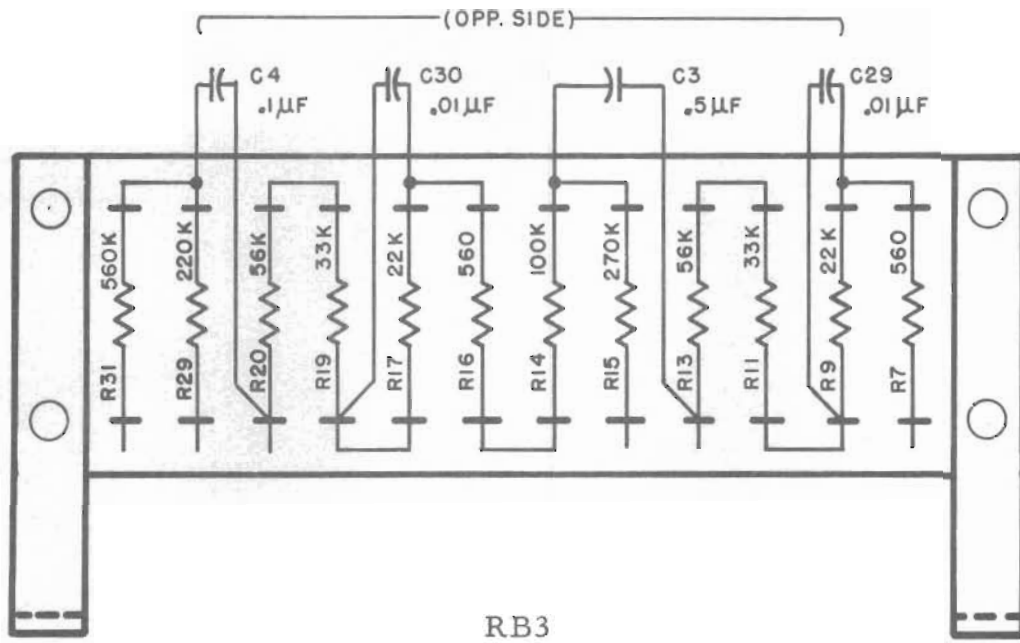

Fig. 6. Model 500A Resistor Board Detail

TABLE OF REPLACEABLE PARTS

Circuit Ref.	Description	-hp- Stock No.	Mfr. * & Mfrs. Designation
C1	Capacitor: fixed, paper, .1 μ f, \pm 10%, 600 vdcw	16-1	CC #73P10496
C2	Capacitor: fixed, electrolytic, 10, 10, 10 μ f, 450 vdcw	18-31	X FPT-389
C3	Capacitor: fixed, paper, .5 μ f, \pm 10%, 400 vdcw	16-58	CC #4TM-P5
C4, C5, C6	Capacitor: fixed, paper, .1 μ f, \pm 10%, 600 vdcw	16-1	CC #73P10496
C7 AB	Capacitor: fixed, electrolytic, 20, 20 μ f, 450 vdcw	18-22	A AEF-"1X3"
C8	Capacitor: fixed, electrolytic, 50 μ f, +200%, -10%, 50 vdcw	18-50	X TC-39
C9 - C28	Part of Range Switch Assembly		
C29, C30	Capacitor: fixed, paper, .01 μ f, \pm 10%, 600 vdcw	16-11	A Type P688
C31	Capacitor: fixed, electrolytic, 20 μ f, 450 vdcw	18-20	X FPS-144
R1, R2, R3	Resistor: fixed, composition, 470,000 ohms, \pm 10%, 1 W	24-470K	B GB 4741
R4	Resistor: fixed, composition, 6.8 megohms, \pm 10%, 1 W	24-6.8M	B GB 6851
R5	Resistor: fixed, composition, 120,000 ohms, \pm 10%, 1 W	24-120K	B GB 1241
R6	Resistor: fixed, composition, 1000 ohms, \pm 10%, 1 W	24-1000	B GB 1021
R7	Resistor: fixed, composition, 560 ohms, \pm 10%, 1 W	24-560	B GB 5611
R8	Resistor: fixed, composition, 1.8 megohms, \pm 10%, 1 W	24-1.8M	B GB 1.851
R9	Resistor: fixed, composition, 22,000 ohms, \pm 10%, 1 W	24-22K	B GB 2231
R10	Resistor: fixed, composition, 3.9 megohms, \pm 10%, 1 W	24-3.9M	B GB 3.951
R11	Resistor: fixed, composition, 33,000 ohms, \pm 10%, 1 W	24-33K	B GB 3331

*See "List of Manufacturers Code Letters For Replaceable Parts Table."

500A 4/24/53 Serial 1765 and above

TABLE OF REPLACEABLE PARTS

Circuit Ref.	Description	-hp- Stock No.	Mfr. * & Mfrs. Designation
R12	Resistor: fixed, composition, 15,000 ohms, $\pm 10\%$, 1 W	24-15K	B GB 1531
R13	Resistor: fixed, composition, 56,000 ohms, $\pm 10\%$, 1 W	24-56K	B GB 5631
R14	Resistor: fixed, composition, 100,000 ohms, $\pm 10\%$, 1 W	24-100K	B GB 1041
R15	Resistor: fixed, composition, 270,000 ohms, $\pm 10\%$, 1 W	24-270K	B GB 2741
R16	Resistor: fixed, composition, 560 ohms, $\pm 10\%$, 1 W	24-560	B GB 5611
R17	Resistor: fixed, composition, 22,000 ohms, $\pm 10\%$, 1 W	24-22K	B GB 2231
R18	Resistor: fixed, composition, 15,000 ohms, $\pm 10\%$, 1 W	24-15K	B GB 1531
R19	Resistor: fixed, composition, 33,000 ohms, $\pm 10\%$, 1 W	24-33K	B GB 3331
R20	Resistor: fixed, composition, 56,000 ohms, $\pm 10\%$, 1 W	24-56K	B GB 5631
R21	Resistor: fixed, composition, 22,000 ohms, $\pm 10\%$, 1 W	24-22K	B GB 2231
R22	Resistor: fixed, composition, 560 ohms, $\pm 10\%$, 1 W	24-560	B GB 5611
R23	Resistor: fixed, composition, 270,000 ohms, $\pm 10\%$, 1 W	24-270K	B GB 2741
R24	Resistor: fixed, composition, 15,000 ohms, $\pm 10\%$, 1 W	24-15K	B GB 1531
R25	Resistor: fixed, composition, 33,000 ohms, $\pm 10\%$, 1 W	24-33K	B GB 3331
R26	Resistor: fixed, composition, 470,000 ohms, $\pm 10\%$, 1 W	24-470K	B GB 4741
R27	Resistor: fixed, wirewound, 100 ohms	5A-26	HP
R28	Resistor: fixed, composition, 100,000 ohms, $\pm 10\%$, 1 W	24-100K	B GB 1041

*See "List of Manufacturers Code Letters For Replaceable Parts Table."

TABLE OF REPLACEABLE PARTS

Circuit Ref.	Description	-hp- Stock No.	Mfr. * & Mfrs. Designation
R29	Resistor: fixed, composition, 220,000 ohms, $\pm 10\%$, 1 W	24-220K	B GB 2241
R30	This circuit reference not assigned		
R31	Resistor: fixed, composition, 560,000 ohms, $\pm 10\%$, 1 W	24-560K	B GB 5641
R32, R33	Resistor: fixed, wirewound, 5000 ohms, $\pm 10\%$, 20 W	27-3	S Type 2R
R34-R43	Electrical value adjusted at factory		
R44	Resistor: fixed, composition, 33 ohms, $\pm 10\%$, 1 W	24-33	B GB 3301
R45	Resistor: fixed, composition, 100,000 ohms, $\pm 10\%$, 1 W	24-100K	B GB 1041
R46	Resistor: fixed, wirewound, 10,000 ohms, $\pm 10\%$, 27 W	27-4	S Type 2R
R47	Resistor: fixed, wirewound, 5000 ohms, $\pm 10\%$, 20 W	27-3	S Type 2R
R48	Resistor: fixed, composition, 33,000 ohms, $\pm 10\%$, 1 W	24-33K	B GB 3331
R49	Resistor: variable, composition, 25,000 ohms, linear taper	210-54	B
R50	Resistor: fixed, composition, 68,000 ohms, $\pm 10\%$, 1 W Electrical value adjusted at factory	24-68K	B GB 6831
R51	Resistor: variable, wirewound, 100 ohms, linear taper	M-80	HP
R52	Resistor: fixed, wirewound, 1000 ohms, $\pm 10\%$, 1 W	26-15	R Type BW-1
R53	Resistor: fixed, composition, 1500 ohms, $\pm 1\%$, 1 W	31-1500	GG Type CP-1
R54	Resistor: fixed, composition, 56,000 ohms, $\pm 10\%$, 1 W	24-56K	B GB 5631
R55	Resistor: variable, wirewound, 50 ohms, $\pm 10\%$, 3 W	210-2	G #21-010-067
R56	Resistor: variable, wirewound, 300 ohms, linear taper	210-53	G #21-010-358

*See "List of Manufacturers Code Letters For Replaceable Parts Table."

500A 5/14/54 Serial 2589 and above

TABLE OF REPLACEABLE PARTS

Circuit Ref.	Description	-hp- Stock No.	Mfr. * & Mfrs. Designation
R57	Electrical value adjusted at factory		
R58, R59	Resistor: fixed, composition, 100,000 ohms, $\pm 10\%$, 1 W	24-100K	B GB 1041
R60	Resistor: fixed, composition, 56 ohms, $\pm 5\%$, 1 W	24-56-5	B GB 5605
R61	Resistor: fixed, composition, 100,000 ohms, $\pm 10\%$, 1 W Electrical value adjusted at factory	24-100K	B GB 1041
	Binding Post:	10A	HP
CR1-CR4	Crystal Rectifier:	212-G11B	HP
F1	Fuse: 1A, Withstands 200% overload for 25 seconds - for 115V operation	211-18	E, MDL-1
F1	Fuse: 1/2A, Withstands 200% overload for 25 seconds - for 230V operation	211-20	E, MDL-1/2
	Fuseholder:	140-18	E
	Indicator Lamp Assembly:	145-2	BB, #607BS
	Knob: 1-1/2" diam.	37-11	HP
	Knob: 2" diam.	37-13	HP
I1	Lamp:	211-47	O, Mazda #47
J1	Telephone Jack:	124-5	X, #706
J2	Telephone Jack:	124-6	Switchcraft, Inc.
M1	Meter:	112-17	HP
P1	Power Cable:	812-56	HP
L1	Reactor: 6 H @ 125 MA, 240 ohms	911-4	HP
S1 AB	Rotary Switch:	310-69	HP
S2	Push Button Switch:	310-53	Switchcraft #1003
S3 ABC, C9-C28	Range Switch Assembly:	5A-19W	HP
S4	Toggle Switch:	310-11	D, 20994NV
T1	Power Transformer:	910-56	HP

*See "List of Manufacturers Code Letters For Replaceable Parts Table."

TABLE OF REPLACEABLE PARTS

Circuit Ref.	Description	-hp- Stock No.	Mfr. * & Mfrs. Designation
V1, V2, V3	Tube: 6SJ7	212-6SJ7	ZZ
V4, V5	Tube: 6V6	212-6V6	ZZ
V6	Tube: 5Y3GT	212-5Y3GT	ZZ
V7	Tube: 6L6	212-6L6	ZZ
V8	Tube: OD3	212-OD3	ZZ

*See "List of Manufacturers Code Letters For Replaceable Parts Table."

500A 5/14/54 Serial 2589 and above

LIST OF MANUFACTURERS CODES

CODE LETTER	MANUFACTURER	ADDRESS	CODE LETTER	MANUFACTURER	ADDRESS
A	Aerovox Corp.	New Bedford, Mass.	AK	Hammerlund Mfg. Co., Inc.	New York 1, N. Y.
B	Allen-Bradley Co.	Milwaukee 4, Wis.	AL	Industrial Condenser Corp.	Chicago 18, Ill.
C	Amperite Co.	New York, N. Y.	AM	Insuline Corp. of America	Manchester, N. H.
D	Arrow, Hart & Hegeman	Hartford, Conn.	AN	Jennings Radio Mfg. Corp.	San Jose, Calif.
E	Bussman Manufacturing Co.	St. Louis, Mo.	AO	E. F. Johnson Co.	Waseca, Minn.
F	Carborundum Co.	Niagara Falls, N. Y.	AP	Lenz Electric Mfg. Co.	Chicago 47, Ill.
G	Centralab	Milwaukee 1, Wis.	AQ	Micro-Switch	Freeport, Ill.
H	Cinch-Jones Mfg. Co.	Chicago 24, Ill.	AR	Mechanical Industries Prod. Co.	Akron 8, Ohio
HP	Hewlett-Packard Co.	Palo Alto, Calif.	AS	Model Eng. & Mfg., Inc.	Huntington, Ind.
I	Clarostat Mfg. Co.	Dover, N. H.	AT	The Muter Co.	Chicago 5, Ill.
J	Cornell Dubilier Elec. Co.	South Plainfield, N. J.	AU	Ohmite Mfg. Co.	Skokie, Ill.
K	Hi-Q Division of Aerovox	Olean, N. Y.	AV	Resistance Products Co.	Harrisburg, Pa.
L	Erie Resistor Corp.	Erie 6, Pa.	AW	Radio Condenser Co.	Camden 3, N. J.
M	Fed. Telephone & Radio Corp.	Clifton, N. J.	AX	Shallcross Manufacturing Co.	Collingdale, Pa.
N	General Electric Co.	Schenectady 5, N. Y.	AY	Solar Manufacturing Co.	Los Angeles 58, Calif.
O	General Electric Supply Corp.	San Francisco, Calif.	AZ	Sealectro Corp.	New Rochelle, N. Y.
P	Girard-Hopkins	Oakland, Calif.	BA	Spencer Thermostat	Attleboro, Mass.
Q	Industrial Products Co.	Danbury, Conn.	BC	Stevens Manufacturing Co.	Mansfield, Ohio
R	International Resistance Co.	Philadelphia 8, Pa.	BD	Torrington Manufacturing Co.	Van Nuys, Calif.
S	Lectrohm Inc.	Chicago 20, Ill.	BE	Vector Electronic Co.	Los Angeles 65, Calif.
T	Littlefuse Inc.	Des Plaines, Ill.	BF	Weston Electrical Inst. Corp.	Newark 5, N. J.
U	Maguire Industries Inc.	Greenwich, Conn.	BG	Advance Electric & Relay Co.	Burbank, Calif.
V	Micamold Radio Corp.	Brooklyn 37, N. Y.	BH	E. I. DuPont	San Francisco, Calif.
W	Oak Manufacturing Co.	Chicago 10, Ill.	BI	Electronics Tube Corp.	Philadelphia 18, Pa.
X	P. R. Mallory Co., Inc.	Indianapolis, Ind.	BJ	Aircraft Radio Corp.	Boonton, N. J.
Y	Radio Corp. of America	Harrison, N. J.	BK	Allied Control Co., Inc.	New York 21, N. Y.
Z	Sangamo Electric Co.	Marion, Ill.	BL	Augat Brothers, Inc.	Attleboro, Mass.
AA	Sarkes Tarzian	Bloomington, Ind.	BM	Carter Radio Division	Chicago, Ill.
BB	Signal Indicator Co.	Brooklyn 37, N. Y.	BN	CBS Hytron Radio & Electric	Danvers, Mass.
CC	Sprague Electric Co.	North Adams, Mass.	BO	Chicago Telephone Supply	Elkhart, Ind.
DD	Stackpole Carbon Co.	St. Marys, Pa.	BP	Henry L. Crowley Co., Inc.	West Orange, N. J.
EE	Sylvania Electric Products Co.	Warren, Pa.	BQ	Curtiss-Wright Corp.	Carlstadt, N. J.
FF	Western Electric Co.	New York 5, N. Y.	BR	Allen B. DuMont Labs	Clifton, N. J.
GG	Wilkor Products, Inc.	Cleveland, Ohio	BS	Excel Transformer Co.	Oakland, Calif.
HH	Amphenol	Chicago 50, Ill.	BT	General Radio Co.	Cambridge 39, Mass.
II	Dial Light Co. of America	Brooklyn 37, N. Y.	BU	Hughes Aircraft Co.	Culver City, Calif.
JJ	Leecraft Manufacturing Co.	New York, N. Y.	BV	International Rectifier Corp.	El Segundo, Calif.
KK	Switchcraft, Inc.	Chicago 22, Ill.	BW	James Knights Co.	Sandwich, Ill.
LL	Gremar Manufacturing Co.	Wakefield, Mass.	BX	Mueller Electric Co.	Cleveland, Ohio
MM	Carad Corp.	Redwood City, Calif.	BY	Precision Thermometer & Inst. Co.	Philadelphia 30, Pa.
NN	Electra Manufacturing Co.	Kansas City, Mo.	BZ	Radio Essentials Inc.	Mt. Vernon, N. Y.
OO	Acro Manufacturing Co.	Columbus 16, Ohio	CA	Raytheon Manufacturing Co.	Newton, Mass.
PP	Alliance Manufacturing Co.	Alliance, Ohio	CB	Tung-Sol Lamp Works, Inc.	Newark 4, N. J.
QQ	Arco Electronics, Inc.	New York 13, N. Y.	CD	Varian Associates	Palo Alto, Calif.
RR	Astron Corp.	East Newark, N. J.	CE	Victory Engineering Corp.	Union, N. J.
SS	Axel Brothers Inc.	Long Island City, N. Y.	CF	Weckesser Co.	Chicago 30, Ill.
TT	Belden Manufacturing Co.	Chicago 44, Ill.	CG	Wileco Corporation	Indianapolis, Ind.
UU	Bird Electronics Corp.	Cleveland 14, Ohio	CH	Winchester Electronics, Inc.	Santa Monica, Calif.
VV	Barber Colman Co.	Rockford, Ill.	CI	Malco Tool & Die	Los Angeles 42, Calif.
WW	Bud Radio Inc.	Cleveland 3, Ohio	CJ	Oxford Electric Corp.	Chicago 15, Ill.
XX	Allen D. Cardwell Mfg. Co.	Plainville, Conn.	CK	Camloc-Fastener Corp.	Paramus, N. J.
YY	Cinema Engineering Co.	Burbank, Calif.	CL	George K. Garrett	Philadelphia 34, Pa.
ZZ	Any brand tube meeting RETMA standards.		CM	Union Switch & Signal	Swissvale, Pa.
AB	Corning Glass Works	Corning, N. Y.	CN	Radio Receptor	New York 11, N. Y.
AC	Dale Products, Inc.	Columbus, Neb.	CO	Automatic & Precision Mfg. Co.	Yonkers, N. Y.
AD	The Drake Mfg. Co.	Chicago 22, Ill.	CP	Bassick Co.	Bridgeport 2, Conn.
AE	Elco Corp.	Philadelphia 24, Pa.	CQ	Birnbach Radio Co.	New York 13, N. Y.
AF	Hugh H. Eby Co.	Philadelphia 44, Pa.	CR	Fischer Specialties	Cincinnati 6, Ohio
AG	Thomas A. Edison, Inc.	West Orange, N. J.	CS	Telefunken (c/o MVM, Inc.)	New York, N. Y.
AH	Fansteel Metallurgical Corp.	North Chicago, Ill.	CT	Potter-Brumfield Co.	Princeton, Ind.
AI	General Ceramics & Steatite Corp.	Keasbey, N. J.	CU	Cannon Electric Co.	Los Angeles, Calif.
AJ	The Gudeman Co.	Sunnyvale, Calif.	CV	Dynac, Inc.	Palo Alto, Calif.
			C'W	Good-All Electric Mfg. Co.	Ogallala, Nebr.



WARRANTY

All our products are warranted against defects in materials and workmanship for one year from the date of shipment. Our obligation is limited to repairing or replacing products (except tubes) which prove to be defective during the warranty period. We are not liable for consequential damages.

For assistance of any kind, including help with instruments under warranty, contact your authorized  Sales Representative for instructions. Give full details of the difficulty and include the instrument model and serial numbers. Service data or shipping instructions will be promptly sent to you. There will be no charge for repair of instruments under warranty, *except transportation charges*. Estimates of charges for non-warranty or other service work will always be supplied, if requested, before work begins.

CLAIM FOR DAMAGE IN SHIPMENT

Your instrument should be inspected and tested as soon as it is received. The instrument is insured for safe delivery. If the instrument is damaged in any way or fails to operate properly, file a claim with the carrier or, if insured separately, with the insurance company.

SHIPPING

On receipt of shipping instructions, forward the instrument prepaid to the destination indicated. You may use the original shipping carton or any strong container. Wrap the instrument in heavy paper or a plastic bag and surround it with three or four inches of shock-absorbing material to cushion it firmly and prevent movement inside the container.

GENERAL

Your authorized  Sales Representative is ready to assist you in any situation, and you are always welcome to get directly in touch with Hewlett-Packard service departments:

CUSTOMER SERVICE

Hewlett-Packard Company
395 Page Mill Road
Palo Alto, California, U.S.A.
Telephone: (415) 326-1755
TWX No. PAL AL 117-U
Cable: "HEWPACK"

OR (In Western Europe)

Hewlett-Packard S.A.
54-54bis Route Des Acacias
Geneva, Switzerland
Telephone: (022) 42. 81. 50
Cable: "HEWPACKSA"



